

## Leakage Current - Part 2

Part 1 of this two-part reference on leakage current discussed the terms and definitions associated with leakage current and the two classes that electronic medical products are divided into per IEC60601-1. Part 2 builds on those basic principles and details the IEC60601-1 measurement circuits for Earth, Touch/Chassis and Patient leakage current tests.

There are some general rules that should be followed when performing a leakage current measurement. The product being tested should be placed on an insulating surface and significantly far away, 20cm, from any earthed metal surface. The measurement circuit and cables should be positioned as far away from unscreened power supply leads as possible and significantly far away from any earthed metal surface.

Recall from Part 1 the human body impedance circuit as illustrated in Figure 1. This circuit is represented as MD in the circuit diagrams for Earth, Touch/Chassis and Patient leakage current tests. Table 1 lists the LC Test figure numbers for this application note and IEC60601-1.

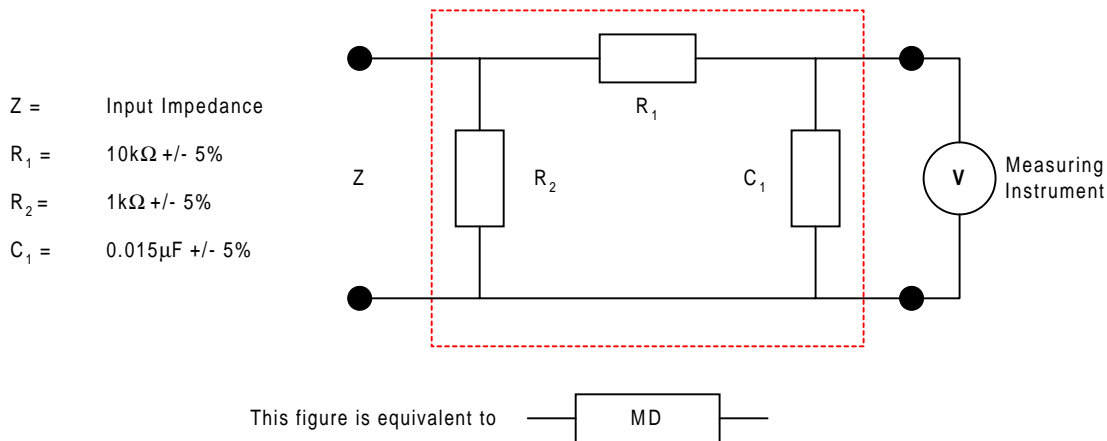

**Figure 1.0: Equivalent Circuit - Human Body Impedance**

**Table 1.0: Reference Figures for LC Tests**

Leakage Current Test	App Note Figure #	IEC60601-1 Figure #
Earth	2.0	12
Touch/Chassis (Enclosure)	3.0	13
Patient, Applied Part to GND	4.0	14
Patient, F-TYPE Applied Part to GND	5.0	15
Patient, Applied Part to GND by SIP/SOP	6.0	16
Patient Auxiliary	7.0	17

## Earth Leakage Current

One of the most important of the leakage current tests for Class I products is earth line leakage. The earth leakage current test measures the leakage current flowing back through the protective earth conductor of the power cord. This is the total leakage current from all protectively earthed parts of the product. This test is only applicable to protectively earthed products that have a three-prong power cord.

Figure 2 illustrates the basic connections to a medical product for earth leakage measurements. The actual leakage current is measured in the box marked **MD**. This is a point in the protective earth conductor between the products protective earth terminal and reference ground. Depending upon the configuration reference ground can also be mains supply ground. Earth leakage measurements are normally made under the following mains supply conditions:

Normal Mains: S5 down position

Reverse Mains: Hot and Neutral reversed S5 up position as shown

Single Fault – Normal: Neutral open S1 open and S5 down

Single Fault – Reverse: Hot and Neutral reversed with Neutral open S1 open and S5 up

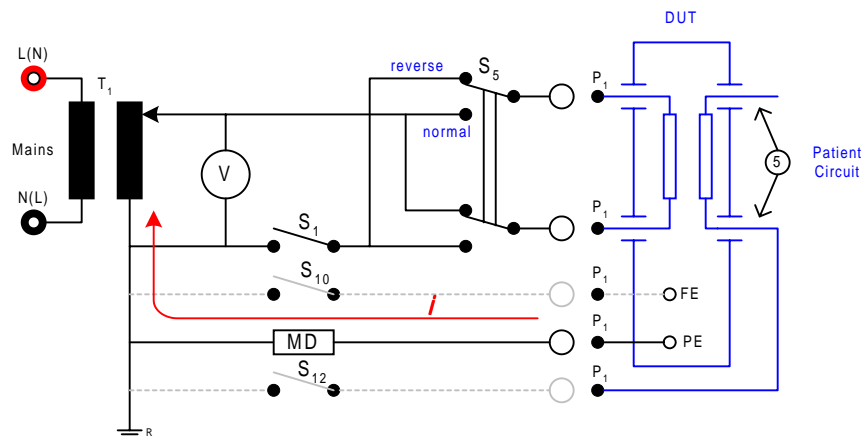

**Figure 2.0: Earth Leakage Current with or without Applied Part  
(Figure 12 of IEC60601-1)**

### List of Abbreviations used in Circuit Diagrams

FE	Functional Earth	①	Medical electrical equipment enclosure
PE	Protective Earth	②	Separate power supply
MD	Measuring Device	③	
S <sub>1</sub> S <sub>2</sub> S <sub>3</sub>	Commutator switch reverses polarity of MAINS voltage	④	Internal electrical power source
S <sub>8</sub>	Single pole switch simulates interruption of single PE conductor	⑤	Patient Circuit (medical device)
S <sub>10</sub> S <sub>11</sub>	Switches to connect FE terminal to earthed point of measuring supply system	⑥	
S <sub>12</sub>	Switch to connect F-type Applied Part to earthed point of measuring supply system		
S <sub>13</sub>	Switch to connect earth to metal Accessible Part that is not an Applied Part or PE		
T <sub>1</sub> T <sub>2</sub>	1-, 2- or polyphase isolation transformers		
V <sub>1</sub> V <sub>2</sub>	Voltmeter including rms value		
P <sub>1</sub>	Socket, plug or terminal for supply connection of medical electrical equipment		
P <sub>2</sub>	Socket, plug or terminal for connection to other equipment in a medical electrical system		
-----	Optional Connection		

## Touch/Chassis or Enclosure Leakage Current

Touch/Chassis or enclosure leakage current measures the leakage current from all parts of the enclosure not connected to protective earth, excluding applied parts. There is also a measurement during a single fault condition, protective earth conductor being open (S7 open), where the leakage current is measured from any part of the enclosure plus contact with any part that is normally protectively earthed. This measurement is basically the summation of earth leakage current and enclosure leakage current. The leakage current measurement device MD is connected between reference ground and any exposed metal on enclosure. To achieve measurements on products that have an enclosure made of insulating material, which is typical of Class II products, a piece of conductive foil no larger than 20cm x 10cm is placed in direct contact with the surface of the enclosure. The foil is normally shifted to determine the highest value of leakage current.

For medical devices touch/chassis leakage current is normally performed with signal inputs and outputs connected to a voltage using a separate transformer. The voltage supplied to the signal inputs and outputs is either based upon the voltage rating supplied by documentation from the manufacturer or 110% of the mains supply voltage. This is shown as T2 in Figure 3.

Measurement of Touch/Chassis (enclosure) leakage is performed under the following conditions:

Normal Mains:  
S5 down position

Reverse Mains:  
Hot and Neutral reversed  
S5 in up position as shown

Single Fault - Normal:  
Neutral open S1 open  
and S5 down

Single Fault - Reverse:  
Hot and Neutral reversed  
with Neutral open, S1 open & S5 up

Single Fault - Ground  
Open: (S7 Open)

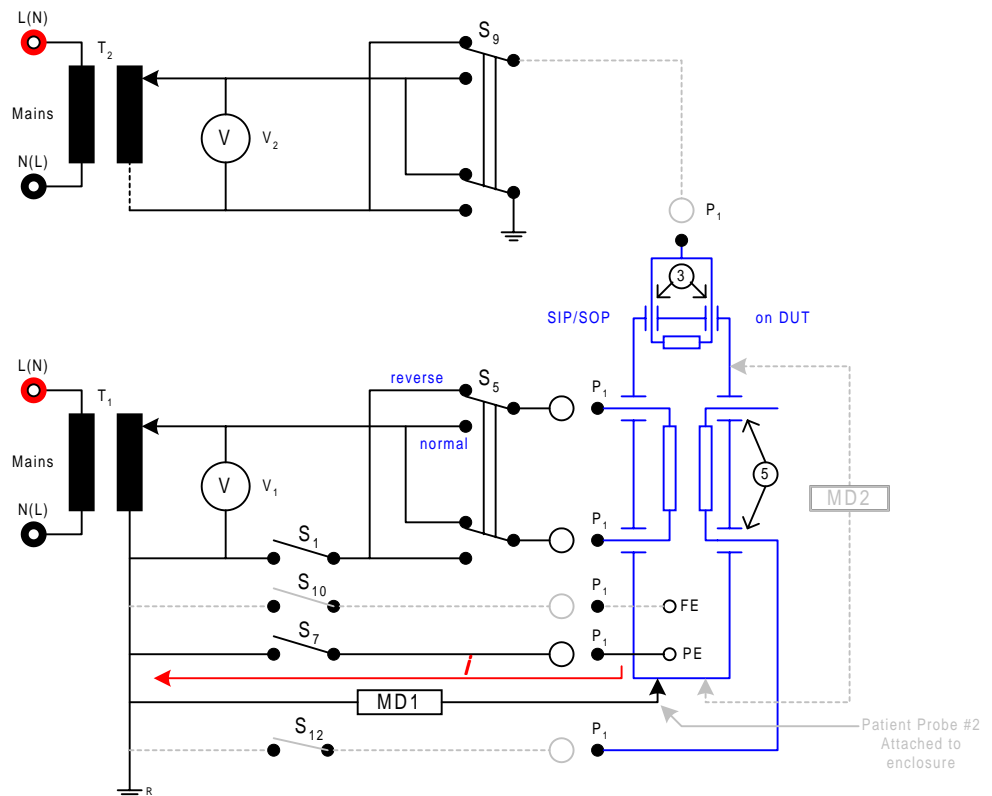

**Figure 3.0: Enclosure (Touch/Chassis) Leakage Current  
(Figure 13 of IEC60601-1)**

## Patient Leakage Current – Applied Part to Supply Ground

Patient leakage current is only a requirement for medical devices. Patient leakage current measures the leakage between any applied part(s) and reference ground using the same standard measuring device MD. The leakage current measurement device MD is connected between supply ground and any exposed metal on applied part. To achieve measurements on products that have an applied part made of insulating material, a piece of conductive foil no larger than 20cm x 10cm is placed in direct contact with the surface of the applied part or a saline solution in which the applied part is immersed maybe used.

Patient leakage is measured under the same normal and fault conditions as outlined in touch/chassis leakage current. Depending upon the Type of patient connection depends upon the number of measurements required. For example leakage current shall be measured from all B-Type applied parts tied together where for products with CF-Type applied parts leakage current has to be measured to each CF-Type applied part separately.

There are a number of considerations when it comes to patient leakage current measurements. If the medical device contains an F-Type Applied Part then the device is tested according to Figure 5 (Figure 15 from IEC601-1) with all signal input and outputs tied to ground.

If the medical device does not have F-Type Applied Parts but contains signal inputs and outputs then the device is tested according to Figure 6.0 (IEC60601-1, Figure 16). In this case the patient leakage current is measured between the applied part(s) and supply ground with all signal inputs and outputs connected to a voltage using a separate transformer. The voltage supplied to the signal inputs and outputs is either based upon the voltage rating supplied by documentation from the manufacturer or 110% of the mains supply voltage. This is shown as T2 in Figure 6.0.

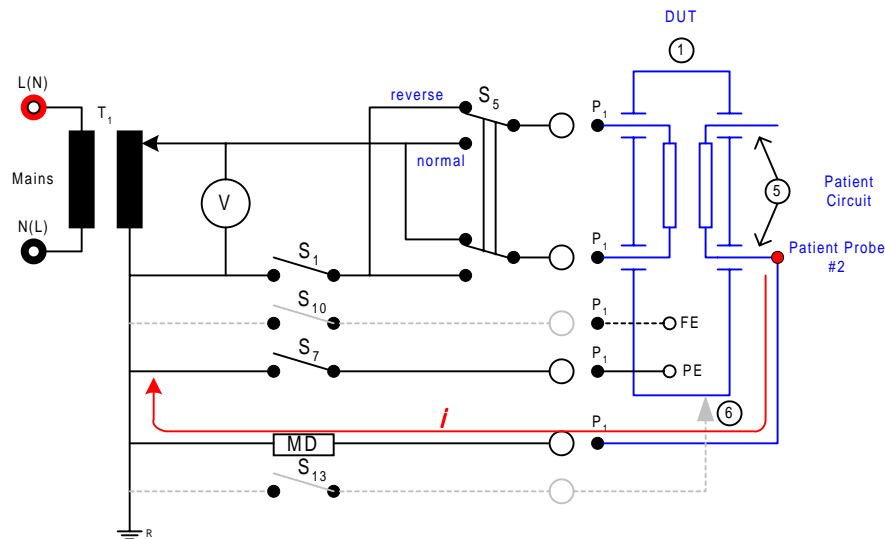

**Figure 4.0: Patient Leakage - Applied Part to Ground  
(Figure 14 of IEC60601-1)**

## Patient Leakage Current – Applied Part to Supply Ground

Figures 5 and 6 illustrate Figures 15 and 16 respectively from IEC60601-1.

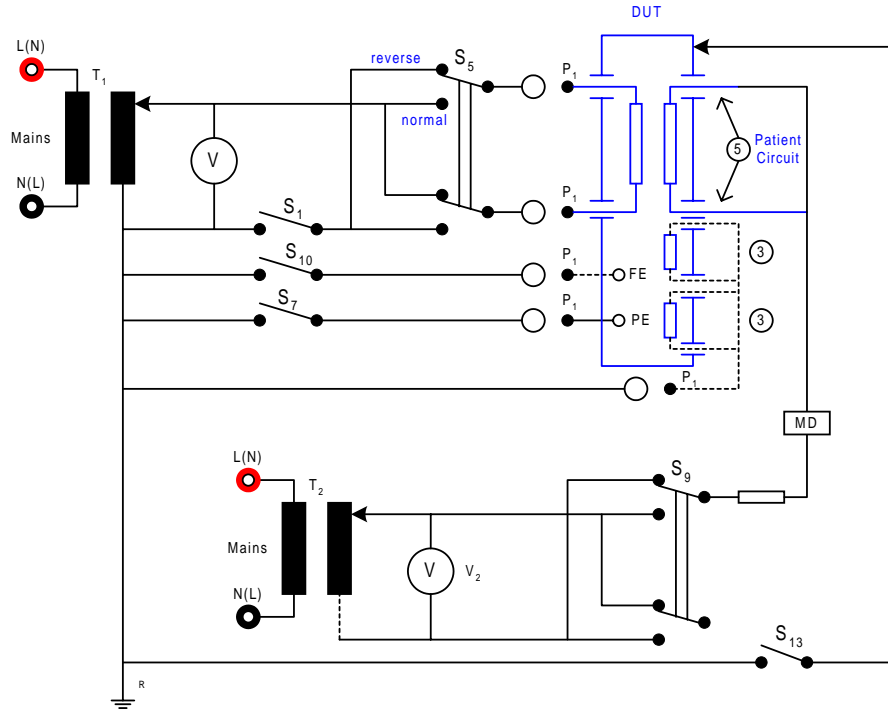

**Figure 5.0: Patient Leakage – F-TYPE Applied Part to Ground** (Figure 15 of IEC60601-1)

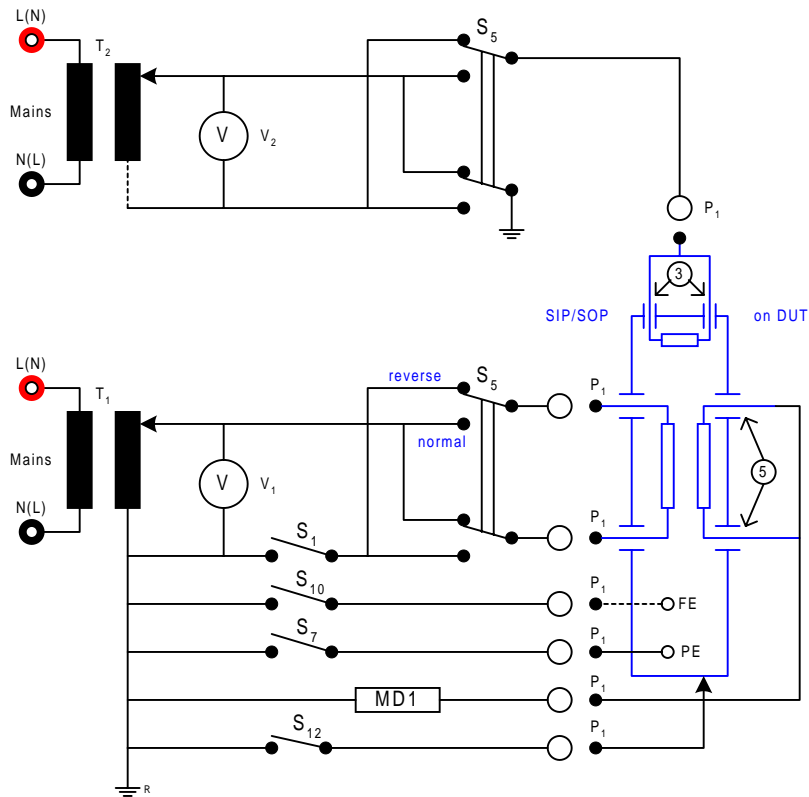

**Figure 6.0: Patient Leakage - Applied Part to Ground by SIP/SOP** (Figure 16 of IEC60601-1)

## Patient Auxiliary Current

Patient Auxiliary current measures the leakage current between one applied part and all others for all possible combinations. The IEC 60601-1 measuring circuit for the patient auxiliary current test is illustrated in Figure 7.0. All of the same normal and fault conditions as outlined in touch/chassis leakage current.

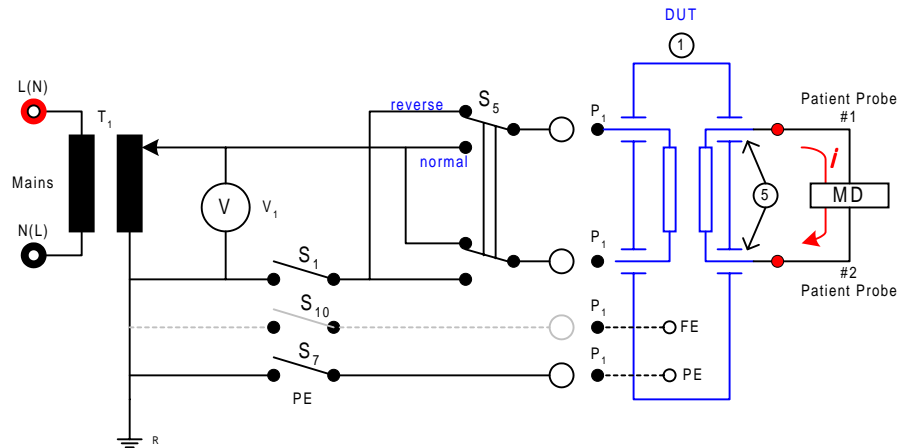

**Figure 7.0: Patient Auxiliary Current (Figure 17 of IEC60601-1)**

This installment (#7) of the IEC60601-1 Series has illustrated the types of leakage tests performed on electronic medical devices. Tune in next time when the discussion will focus on national deviations to IEC60601-1, like AAMI, ES-1 and NFPA 99.



To find out more about IEC60601-1 and classification please contact Eisner Safety Consultants at (805)-884-9680 visit us on the web at <http://www.eisnersafety.com/> or e-mail us at [Leo@EisnerSafety.com](mailto:Leo@EisnerSafety.com). Eisner Safety Consultants specializes in assisting clients with product evaluation to safety standards, Agency coordination, CE Mark, Quality Systems and training.

For complete product specifications on the 6100 Production Safety Analyzer for Electronic Medical Devices or any of QuadTech's products, visit us at <http://www.quadtech.com/products>. Call us at 1-800-253-1230 or email your questions to [info@quadtech.com](mailto:info@quadtech.com).

### DISCLAIMER

The organizations listed in this application note do **not** have any formal relationship, agreement or representation with Eisner Safety Consultants or QuadTech, Incorporated. The web links to these organizations are provided for general information only.

The information presented here is subject to change and is intended for general information only

©QuadTech, Incorporated

Telephone: 1- 800-253-1230, Website: <http://www.quadtech.com>

Printed in U.S.A.

P/N 035118/A1

August 2002